

# TOBROCO

GROUP

## OPERATOR MANUAL

### S54B VIBRATORY RAMMER

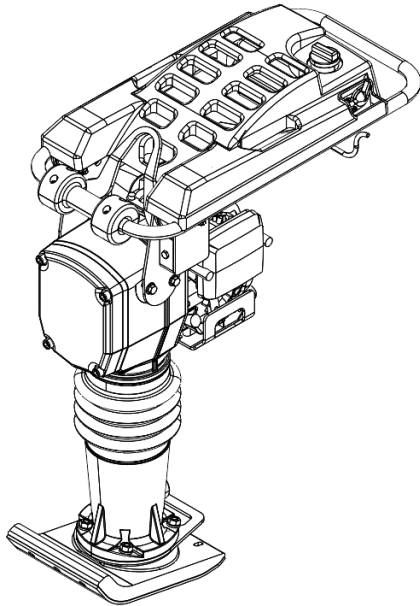

EN - Original Manual



Please carefully read and understand the contents of this manual. Failure to read the manual can result in serious damage, injury or death. Keep this manual with the machine at all times. Make sure that all operators of the machine have read and understood the contents of this manual.

Copyright © TOBROCO Machines BV

TOBROCO Machines BV reserves the right to change specifications and or parts without prior notice. The content of this manual can also be changed without prior notice.

For information about settings, maintenance or repairs not provided for in this manual, please contact the dealer.

TOBROCO Machines BV accepts no liability for damage and/or problems arising from the use of parts which have not been supplied by TOBROCO Machines BV.

This manual was created with the utmost care. TOBROCO Machines BV assumes no responsibility for any errors in this manual and/or the consequences of an erroneous interpretation of the instructions.

All rights reserved. No parts of this publication are allowed to be reproduced, stored in computerised databases, or made public, in any form or by any means, either electronic, mechanical, through photocopying or otherwise, without the prior written consent of TOBROCO Machines BV. This also applies to the associated drawings and diagrams.

# Preface

This is the operator manual of the S54B. This document is for approved operators. Refer to *Approved operator* on page 25 for more information. This document gives the information that is necessary to operate and perform first-line maintenance on the machine.

The operator manual provides detailed operating procedures for safe, effective and proper use of the machine. Safe operation is detailed in chapter *Safety* on page 19. Specifications, first-line maintenance and troubleshooting information are also included in this manual.

Improper operation, inspection and maintenance of the machine can result in injury or death. Read and understand the contents of this manual completely and become familiar with the machine before operation. Contact the authorized TOBROCO Machines BV dealer with any questions about information in this manual, if extra manuals are required, or about availability of manuals in other languages.

## Language



If this machine is located in the United States of America:

- Only use the EN-US version of this document to use the machine or perform maintenance on the machine.
- If this document is not the EN-US version, please ask the TOBROCO Machines BV dealer for an EN-US copy.
- The original instructions in this document are created in English (EN-GB). All other language versions are translations of the original instructions. In the event of ambiguity and/or disputes, the English (EN-GB) text always takes precedence.

## Manual storage

This document is a part of the machine. Make sure that the document is kept in a dry and clean location (e.g. in a document holder) on the machine.

## Icons and signal words used in the document



Warns about a situation that will cause death, serious physical injury and/or heavy material damage if one does not obey the safety instructions.



Warns about a situation that can cause death, serious physical injury and/or heavy material damage if one does not obey the safety instructions.







Warns about a situation that can cause material damage if one does not follow the safety instructions.



Provides additional information that is helpful to do a task or to avoid problems.

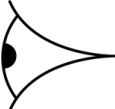

This symbol indicates required tools.

Icon	Meaning
	Indicates that the same part is also present at the opposite side.
	Use a grease gun to lubricate the pivot points.
	Visual inspection.
	Location of an eyelet to tie down the machine.

Icon	Meaning
	Location of an eyelet to lift the machine.

## Illustrations

It is not always possible to show the exact configuration of the machine. The illustrations in this document show a standard set-up. They are for instruction and description purposes only.

## Recommissioning

If the machine is resold, include this operator manual as part of the sale. If a used machine was purchased, or if the owner's address has changed, please provide the TOBROCO Machines BV dealer or TOBROCO Machines BV with the current owner's name and address, along with the machine model and serial numbers. This will allow the registered owner information to be updated, so that the owner can be notified directly in case of important product issues, such as a safety update program.

## Version history

Every effort has been made to make this manual as accurate and complete as possible. If any errors or omissions are discovered, please bring this to the attention of TOBROCO Machines BV, so possible revisions can be made. This will enable the improvement of the documentation.

The instructions in this manual do not take into account different national regulations and laws. When operating the machine, it is the sole responsibility of the operator to make sure that all applicable (local) laws and regulations are obeyed.

During the lifetime of the machine, engineering improvements can result in the need to revise this manual. It is then at the discretion of TOBROCO Machines BV if a revision or new version of this manual is required.

The following table describes the main changes for each document version of this manual.

<b>Version</b>	<b>Changes</b>
R2204	Original edition.
R2208	Operation and Maintenance instructions added; technical specifications engine revised; illustrations updated.
R2211	Technical data revised (rotational speed; oil specifications).
R2212	Safety labels overview revised.
R2304	Safety and technical data revised; EC Declaration of Conformity added.
R2305	Safety and technical data revised.
R2309	Cleaning the machine added.
R2401	Checking and cleaning the air filter revised.
R2402	Instructions revised (cleaning the machine; maintenance schedule; minor textual revisions).

## Typographical conventions

- SI units of measurement are used. If necessary, the document shows imperial or other units of measurement in round brackets: ( ).
- The steps in procedures have numbers (123) if the sequence is important.
- Lists and steps with bullets (•) are used if the sequence is not important.
- Lists with letters (ABC) are used if the sequence is important.
- A text in round brackets (option) indicates that the section applies to an optional part of the machine.

# EC DECLARATION OF CONFORMITY

The manufacturer

**Name:** TOBROCO Machines BV

**Address:** Industrielaan 2  
5061 KC Oisterwijk  
The Netherlands

declares under his sole responsibility that:

**Description:** Vibratory Rammer

**Category:** Compaction machine

**Make/Model:** SAMAC S54B

Is in conformity with:

Directive 2006/42/EC of the European Parliament and of the Council of 17 May 2006 on machinery, and amending Directive 95/16/EC.

Directive 2000/14/EC of the European Parliament and of the Council of 8 May 2000 on the approximation of the laws of the Member States relating to the noise emission in the environment by equipment for use outdoors;

Category: compaction machine; guaranteed sound power level (Lwa): 104 dB(A).

The manufacturer keeps the technical documentation and is authorised to complete the technical file.

Oisterwijk,

A.J.J. Brock  
(CEO)





# Contents

<b>Preface</b> .....	<b>3</b>
Language.....	3
Manual storage.....	3
Icons and signal words used in the document.....	4
Illustrations.....	5
Recommissioning.....	5
Version history.....	5
Typographical conventions.....	6
EC DECLARATION OF CONFORMITY.....	7
<b>1 Introduction</b> .....	<b>11</b>
<b>2 Description</b> .....	<b>13</b>
2.1 Overview.....	13
2.2 Engine.....	14
<b>3 Applications</b> .....	<b>15</b>
<b>4 Technical Data</b> .....	<b>17</b>
4.1 General.....	17
4.2 Engine.....	17
<b>5 Safety</b> .....	<b>19</b>
5.1 Liability.....	19
5.2 General safety rules.....	20
5.3 Before starting the machine.....	22
5.4 During operation.....	23
5.5 Approved operator.....	25
5.6 Electrical energy.....	25
5.7 Personal protective equipment.....	26
5.8 Safety labels.....	27
5.9 New (safety) label application.....	29
5.10 Slopes.....	29
5.11 Terrain.....	30
5.12 Fire and burn hazards.....	30
5.13 Vibration hazards.....	31

---

<b>6 Transport and storage</b> .....	<b>33</b>
6.1 Lifting the machine.....	35
6.2 Moving the machine over a short distance.....	37
<b>7 Commissioning</b> .....	<b>39</b>
<b>8 Operation</b> .....	<b>41</b>
8.1 Starting the engine.....	41
8.2 During operation.....	44
8.3 Switching off the engine.....	45
<b>9 Maintenance</b> .....	<b>47</b>
9.1 Regular maintenance schedule.....	48
9.2 Maintenance for a new machine.....	50
9.3 Cleaning the machine.....	50
9.4 Engine and fuel system maintenance.....	51
9.4.1 Checking and adding engine oil.....	51
9.4.2 Replacing the engine oil.....	52
9.4.3 Checking and adding fuel.....	53
9.4.4 Replacing the in-line fuel filter.....	55
9.5 Frame maintenance.....	56
9.5.1 Cleaning or replacing the air filter unit.....	56
<b>10 Troubleshooting</b> .....	<b>59</b>
10.1 Troubleshooting procedure.....	59
<b>11 Environment</b> .....	<b>61</b>
11.1 Decommissioning and waste disposal.....	61
<b>12 Terms of warranty</b> .....	<b>63</b>
<b>13 Appendix</b> .....	<b>65</b>
13.1 Dealer details.....	65
13.2 Machine-specific information.....	65
13.3 Maintenance Log.....	65

# 1 Introduction

The Vibratory Rammer is suitable for compacting soil. It can be used for several applications.

The machine's compact design offers good accessibility in restricted spaces. Due to the high stroke movement, the machine can be used when the soil is mixed with clay.

The machine uses a combustion engine and must only be used in well-ventilated areas.



## 2 Description

This section provides an overview of the main components and functions.

### 2.1 Overview

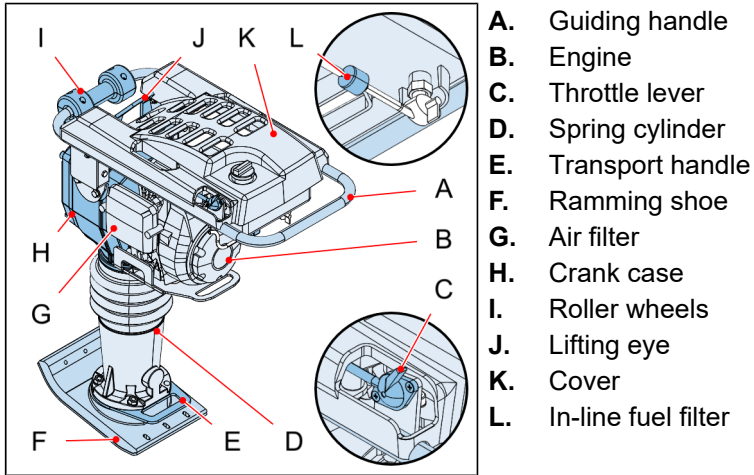

## 2.2 Engine



Illustration(s) can differ from the actual configuration.

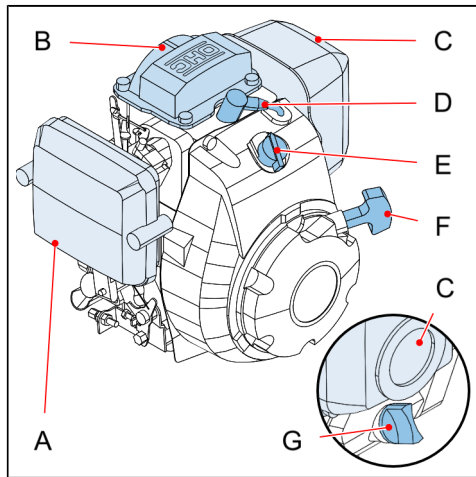

- A.** Air filter
- B.** Engine valves
- C.** Silencer
- D.** Spark plug
- E.** Engine power switch
- F.** Recoil starter (starter cable)
- G.** Oil filler cap/Dipstick

### 3 Applications

**WARNING**

- If operation near edges is required, always keep 2/3 of the machine on the load-bearing surface. This will prevent the machine from slipping or tipping over.
- Do not exceed the maximum slope angle for operation with the machine. This can cause injury or damage to the machine. Refer to *Technical Data* on page 17 for more information.



The machine can be used for the following purposes:

- Soil compaction (cohesive, mixed and granular soils in confined areas)
- Asphalt compaction
- Paving stones

**WARNING**

It is **NOT** allowed to use the machine:

- on very cohesive soils
- on frozen soils
- in dry, flammable vegetation
- on hard, non-compressible soils
- on non-load-bearing soils
- in heavy rain on slopes
- in the vicinity of explosive substances
- in potentially explosive areas
- in tunnels or closed spaces
- as a support device (e.g. a makeshift ladder), support, or working surface for other tasks
- as a means of transportation for people or equipment.





## 4 Technical Data

### 4.1 General

**CAUTION**

It is not allowed to modify the engine speed. Observe the strokes per minute as described in the table below.

<b>Machine</b>	
Weight	58 kg
Ramming shoe dimensions	32 × 19/23/28 cm
Ramming cylinder oil	0.55 litre SAE 15w40
Strokes per minute	450-650
Stroke height	62 mm
Compaction depth	50 cm
Impact force	16 kN
Noise level $L_p$	94 dB
Noise level $L_w$	104 dB
Hand-arm vibration	7.1 m/s <sup>2</sup> (EN 500-4, ISO 5349, EN1033)

### 4.2 Engine

<b>Engine</b>	
Make/model	Honda GXR120 KREU
Power	2.7 kW
Cylinder capacity	121 cm <sup>3</sup>
Rotational speed	3600 rpm
Air filter	Dry

<b>Engine</b>	
Fuel	Premium unleaded petrol Octane: min. 86 Added ethanol: max. 5 %.
	Aspen 4
Engine oil	0.3 litre SAE 15w40
Engine emissions	Stage V (EU 2016/1628)

## 5 Safety



### **WARNING**

This chapter is about security and safe operation of the machine. Carefully read all safety messages in this manual and the safety signs on the machine. Keep safety labels in good condition. Replace missing or damaged safety labels. Make sure that new equipment, components and repair parts include the correct safety labels. Replacement safety labels are available via the TOBROCO Machines BV dealer.



### **WARNING**

Some parts and components are sourced from third-party suppliers and can therefore show additional safety information that is not included in this operator manual.

### 5.1 Liability



### **CAUTION**

TOBROCO Machines BV is not responsible for direct and indirect damage caused by operator error, lack of maintenance or any other use other than described in this document.

The liability of TOBROCO Machines BV is also void when modifications or extensions are applied to the machine or to accessories without the written consent of TOBROCO Machines BV.

It is the responsibility of the owner to make sure that:

- Only approved operators operate and perform operator maintenance on the machine.
- Only approved service engineers perform other service tasks on the machine.

## 5.2 General safety rules



- All instructions regarding the correct use, residual risk, installation, operation and maintenance contained in this operator manual must be noted and observed.
- Never modify or disable safety devices that are installed on the machine. This can lead to serious injuries or damage to the machine.
- It is not allowed to adjust the pre-set engine speed. This can cause damage to the engine.
- Always switch off the machine when it is not in operation.
- Close the fuel tap when the machine is not in operation.
- Do not use this machine for purposes other than described in this operator manual.
- Make sure that the operator knows the worksite hazards and the (local) laws and regulations. The information in this document does not replace any applicable (local) laws or regulations.
- If local laws or regulations are stricter than national laws, the local laws or regulations will prevail.
- Compaction work can cause damage to nearby buildings. The operator must always check the surroundings before using the machine.
- When operating the machine on a slope, always make sure that the machine is facing the bottom of the slope and the operator is at the top side of the slope.
- The operator should never leave a working machine unattended.
- Keep body parts and clothing away from moving parts.
- Always wear personal protective equipment when working with the machine. Refer to *Personal protective equipment* on page 26.

- Avoid skin contact with fuels, oils and lubricants. Wear protective clothing, such as safety glasses and gloves. Upon contact, wash immediately with soap and water. In case of contact with eyes, rinse immediately with running water for at least 10 minutes and immediately get medical attention. Provide sufficient water and soap and make sure that there is assistance in vocal range when performing work.
- Make sure that there is enough ventilation and aeration when the machine is used in partially closed areas. Do not inhale exhaust fumes. This can cause serious injury or death.
- Keep children away from the machine at all times.
- Do not make any modifications to the machine without the written consent of TOBROCO Machines BV.
- Make sure that all maintenance is done correctly and at the correct maintenance intervals. Refer to *Maintenance* on page 47.
- Do not smoke when filling the fuel tank, when working with the machine, or when servicing the machine.
- Before starting the machine, make sure that all maintenance tools are removed from the machine. A loose tool or object can be flung from the machine and cause serious injury or damage.
- Make sure that the machine cannot fall over, slip, slide, roll or tip over during operation and when the machine is not in operation.
- If the machine falls over during operation, first switch off the engine before attempting to place the machine back into the operating position.
- The operator should be aware of what to do in case of an emergency.

 **CAUTION**

- Never work on hard surfaces (e.g. solid rock or hardened concrete).
- When working in trenches: always make sure that the trench is wide enough. When working in a narrow trench, the ramming shoe can get caught between the sides of the trench. This can cause the machine to misstrike, resulting in severe damage to the machine.
- Make certain that the machine is only steered by using the hand grip. Only push the machine. Never press the machine into the materials that are being compacted.

### 5.3 Before starting the machine

 **WARNING**

- Walk around the machine and inspect it before using it. Look for damage, loose or missing parts, leaks, damaged safety labels, etc. Do not use a machine with defective, missing or damaged components or operator controls.
- Replace a lost or damaged operator manual.
- To make sure that operations are safe: replace damaged or worn-out parts with genuine service parts.
- To minimize the risk of fire: daily remove all trash and debris from the machine. The operator's area, such as the handholds, must be free of oil, dirt, ice and loose objects.
- Make sure that all safety provisions on the machine are present and function correctly.
- Do not start the machine if there is any indication that maintenance or service work is in progress, or if a warning tag is attached to the controls.
- Warn all nearby personnel before starting the machine.
- Before working near power lines (either above-ground or buried cable type), always contact the power utility and establish a safety plan with them.

- Terrain and soil conditions at the worksite, approaching traffic, weather-related hazards and any above- or below-ground obstacles and hazards should be observed and monitored by all work crew members.
- Remove jewellery, tie back long hair, and do not put on loose-fitting garments that can be caught in moving parts of the machine.
- Do not use starting aids beside the engine pre-heating. Engine pre-heating can cause ether or other starting aids to detonate, causing injury or damage.
- Do not start the machine or operate controls from a location other than the operator's area.
- Only start the machine and operate the controls when the operator is located in the operator's area.
- Do not short-circuit a starter terminal to start the engine. Obey the instructions in *Operation* on page 41. If these instructions are not followed, this can cause unwanted and sudden movement of the machine. This can cause injury.
- If applicable: make sure that the direction lever is in the [MID/Stationary]-position.
- Poor visibility can cause accidents. Always make sure that the working surface is clearly visible.

## 5.4 During operation



DISREGARDING ANY OF THESE FACTORS CAN RESULT IN DEATH OR SERIOUS INJURY, OR DAMAGE TO THE MACHINE.

- Exhaust fumes can kill. Make sure that there is sufficient airflow around the machine to remove the exhaust gases. Risk of carbon monoxide (CO) suffocation. CO is present in the exhaust gases and is odourless and lethal. Do not start or operate the engine indoors.

- Poor visibility can cause accidents. Always make sure that the working surface is clearly visible. Use a signal person if the operator cannot see the entire work area clearly and whenever the operator's view is obstructed.
- Do not use the machine too close to an excavation or ditch. Make sure that the surrounding ground has adequate strength to support the machine.
- When having to operate the machine in ditches or pitches, always pay attention to the side walls. These can collapse due to vibration.
- If applicable: snow accumulation can hide potential hazards. Use care while operating the machine.
- The operator must remain alert for possible hazardous conditions.
- Be aware of any overhead obstacles.
- Be aware of people moving through the work area.
- Only the operator is allowed on the machine during operation. Keep bystanders away from the machine.
- Always wear personal protective equipment. Refer to *Personal protective equipment* on page 26.
- Keep hands, head and feet inside the operator's area when operating the machine.
- Only start the machine while keeping a firm grip on the machine's control handle(s).
- Control the machine cautiously and gradually until fully familiar with all the controls and handling. New operators must first operate the machine in an open area away from bystanders. Practice with the controls until the machine can be operated safely and efficiently.
- When the machine is damaged, malfunctions or the operator hears an unusual noise, stop the machine immediately and make sure that no person uses it. Make sure that the damage is repaired and/or the problem solved before using the machine again.
- Always observe the technical specifications of the machine during operation. Refer to *Technical Data* on page 17.
- Adjust the machine speed to the applicable working conditions.
- Never put body parts near moving parts. Moving parts can cause injury.
- Do not use the machine to lift or transport people. Do not allow others to ride on the machine, because they can fall off or cause an accident.
- If applicable: look over both shoulders to the rear before using the machine in reverse.



## 5.5 Approved operator



### WARNING

- If the operator is not yet 18 years old, supervision by another approved operator who is > 18 years old is required.
- Only approved operators are allowed to perform the work shown in this document.

All operators of the machine must:

- be mentally and physically capable to perform the tasks described in this document.
- know, understand and adhere to the instructions described in this document.
- be over the age of 16.

## 5.6 Electrical energy



### WARNING

Stay away from high-voltage electric lines. Serious injury or death can result from contact or proximity to high-voltage electric lines. The machine does not have to make physical contact with power lines for any current to be transmitted. Use a spotter and hand signals to keep away from power lines that are not clearly visible to the operator.



### WARNING

Depending upon the voltage in the power line and atmospheric conditions, strong current shocks can occur if the machine is within 3 m (10 ft.) to the power line. Very high voltage and rainy weather can further increase the safe operating distance.

 **WARNING**

If the machine comes into contact with a live wire:

- Warn others not to approach or touch the machine.
- Have the live wire de-energized.
- Do not approach the machine until the wire has been safely de-energized.

- If applicable: work on the machine's electrical system must be performed by licensed technicians only.
- If applicable: inspect and check the machine's electrical equipment at regular intervals. Problems that are found, such as loose connections or scorched cables, must be repaired before using the machine.
- If applicable: only use proper, original equipment fuses/circuit breakers with the specified current rating. Immediately switch off the machine, if there is any indication of a problem with the electrical system.

## 5.7 Personal protective equipment

 **WARNING**

Always use approved protective equipment. Operators and all other persons in the working area must wear protective equipment, including at a minimum:

- Protective helmet (also, tie back long hair).
- Hearing protection
- Impact resistant eye protection with side protection
- Respiratory protection when appropriate
- Protective gloves
- Protective boots
- Appropriate work overall or similar (not loose-fitting) clothing that covers arms and legs





 **WARNING** Even with the use of personal protective equipment, it is still possible residual risks are present when using the machine. The operator can still be exposed to:









- Heat, noise, exhaust fumes and carbon monoxide
- Fire hazards from incorrect refuelling
- Fuel and fuel fumes
- Operator errors (incorrect lifting of the machine, incorrect operation of the machine)



## 5.8 Safety labels

 **WARNING**

- If a safety label is damaged or not clearly visible or legible, immediately apply new safety labels. Contact the dealer for more information.
- It is possible that some of these labels in the table below are not present on the machine.

Label	Description
	<ul style="list-style-type: none"> <li>• The operator must carefully read the manual and its safety instructions before using the machine. The operator must know how to operate the machine safely.</li> <li>• Make sure that the manual is always accessible.</li> </ul>
	<p>Hot surface hazard: risk of burns.</p>
	<p>To avoid injury and damage, the operator should keep hands, tools and other objects away from the V-belt when the machine is switched on.</p>
	<ul style="list-style-type: none"> <li>• Always use personal protective equipment (hearing protection).</li> <li>• Risk of hearing damage.</li> </ul>

Label	Description
	<p>Location of an eyelet to lift the machine.</p>
	<p>This is the slow rotational speed indicator.</p>
	<p>This is the fast rotational speed indicator.</p>
	<p>Push the choke lever in this direction to close the choke.</p>
	<p>Fuel tap icon.</p>
	<p>Push the fuel tap lever in this direction to open the fuel tap.</p>
	<p>Max. noise level indicator.</p>
	<p>Dispose of the machine in accordance with (local) laws and regulations.</p>
	<ul style="list-style-type: none"> <li>• Risk of fire. Fuel is flammable.</li> <li>• Do not refuel when the machine is in operation.</li> </ul>

Label	Description
	Risk of fire.
	<ul style="list-style-type: none"> <li>• Exhaust gases can cause injury.</li> <li>• Do not use the machine in confined spaces.</li> </ul>
	

### 5.9 New (safety) label application

Before applying new (safety) labels, the applicable surfaces on the machine must be free of dirt, dust, grease and foreign material(s). Remove the smaller portion of the backing paper of the (safety) label and apply the exposed adhesive to the clean surface, while maintaining proper position and alignment. Peel off the rest of the backing paper and apply pressure by hand to smooth out the surface of the (safety) label.



**WARNING**

When replacing a machine part that has a (safety) label on it, make sure that the replacement part also has the same (safety) label on it.

### 5.10 Slopes



**WARNING**

- When possible, do **NOT** operate the machine on slopes. This can cause personal injury to the operator, or damage to the machine.
- When operation on a slope is necessary, always make sure that the machine is facing the bottom of the slope and the operator is at the top side of the slope.

## 5.11 Terrain

- Make sure that the terrain is firm and can hold the weight of the machine.
- Do not operate the machine on dangerous terrain. This can cause the machine to slip or tip over. Dangerous terrains include:
  - Close to the edges of ditches or banks, which can collapse under the weight of the machine, especially when the ground is loose or wet.
  - Terrain of which the conditions are unknown.
  - Soft terrain, such as landfills.

## 5.12 Fire and burn hazards



- Smoking near the fuel tank is prohibited.
- Keep sparks or open fire away from the fuel tank.
- Keep the machine away from combustible substances. The machine produces hot exhaust gases and possible sparks from the exhaust, which can cause these substances to catch fire.
- When starting the engine, make sure that there are no flammable objects near the engine. Also, keep flammable objects away from an operational machine.
- Switch off the engine before filling up the fuel tank.
- Never remove the fuel tank filler cap when the machine is hot.
- Do not touch the engine or silencer while the engine is on or immediately after it has been switched off. This can cause burns.
- Never fill the fuel tank when the machine is hot.
- Only fill the fuel tank in an area with sufficient airflow.
- Do not overfill the fuel tank.
- Do not spill fuel when filling the fuel tank.
- When the fuel tank is filled, make sure that the fuel tank filler cap is correctly installed again.

## 5.13 Vibration hazards



### WARNING

- During normal and correct use of the machine, the operator is exposed to (strong) vibrations. Regular and frequent exposure to vibrations can cause, contribute to, or aggravate injuries or disorders to the operator's fingers, hands, wrists, arms, shoulders and/or nerves and blood supply, or other parts of the body.
- Regular and frequent exposure to vibrations can also cause debilitating and/or permanent injuries or disorders that can develop gradually over periods of weeks, months or even years. Such injuries or disorders can include damage to the blood circulatory system, damage to the nervous system, damage to joints, and possibly damage to other parts of the operator's body.



### WARNING

- The operator should immediately stop using the machine and seek medical attention if any of the following symptoms occurs: numbness, persistent recurring discomfort, burning sensation, stiffness, throbbing, tingling, pain, clumsiness, weakened grip, whitening of the skin, or any other unspecified symptom.
- Should the operator continue to use the machine after any of these symptoms has occurred, this can increase the risk of symptoms becoming more severe and/or permanent.

 **WARNING**

To prevent an unnecessary increase in vibrations, it is recommended to use and maintain the machine as follows:

- If the machine is equipped with vibration-absorbing handles: keep the handles in a central position and avoid pressing the handles into the end stops.
- The only bodily contact with the machine should be the operator's hands. Avoid any other bodily contact with the machine. Do not support any part of the operator's body against the machine or lean onto the machine to increase the feed force.
- If the machine suddenly starts to vibrate strongly, immediately stop using the machine. Find and remove the cause of the vibrations before putting the machine back into operation.



## 6 Transport and storage



Illustration(s) can differ from the actual configuration.



### WARNING

Do not transport the machine when it is in operation. Always switch off the machine before transporting (lifting or moving) the machine.

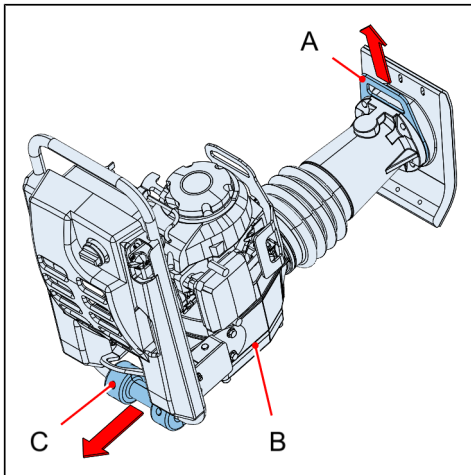

### CAUTION

When the machine (B) is switched off and no longer in use, carefully tilt the machine (B) forwards to make it rest on the roller wheels (C). If necessary, the machine (B) can be rolled backwards or forwards with the transport handle (A).

 **CAUTION**

- It is recommended to empty the fuel tank before transport.
- Keep the machine in the upright position for transport. This will reduce the chance of leaking liquids.
- Make sure that the throttle lever and, if applicable, engine power switch are in the [OFF]-position.
- If the fuel tank cannot be emptied prior to transport: always make sure that the fuel tank is completely closed, before preparing the machine for transport. Keep the fuel tank closed during transport.
- When possible, store the machine in a dry location. Humidity can cause rust and corrosion.

 **CAUTION**

- Use suitable lifting gear to move the machine.
- All lifting gears must be dimensioned for the weight of the machine and be in compliance with all (local) regulations. Refer to *Technical Data* on page 17 for more information.
- Make sure that the ramming shoe is undamaged and correctly attached before lifting the machine.
- Do **not** use the guiding handle to lift the machine for transport.



For the weight of the machine, refer to *Technical Data* on page 17 or the identification plate on the machine.

## 6.1 Lifting the machine



Illustration(s) can differ from the actual configuration.

### CAUTION

- Use suitable lifting gear (B) to lift the machine.
- All lifting gears must be dimensioned for the weight of the machine and be in compliance with all (local) regulations. Refer to *Technical Data* on page 17 for more information.
- Make sure that the ramming shoe is undamaged and correctly attached before lifting the machine.
- Do **not** use the guiding handle to lift the machine for transport. For instructions on lifting the machine, refer to *Lifting the machine* on page 35.



Suitable lifting gear

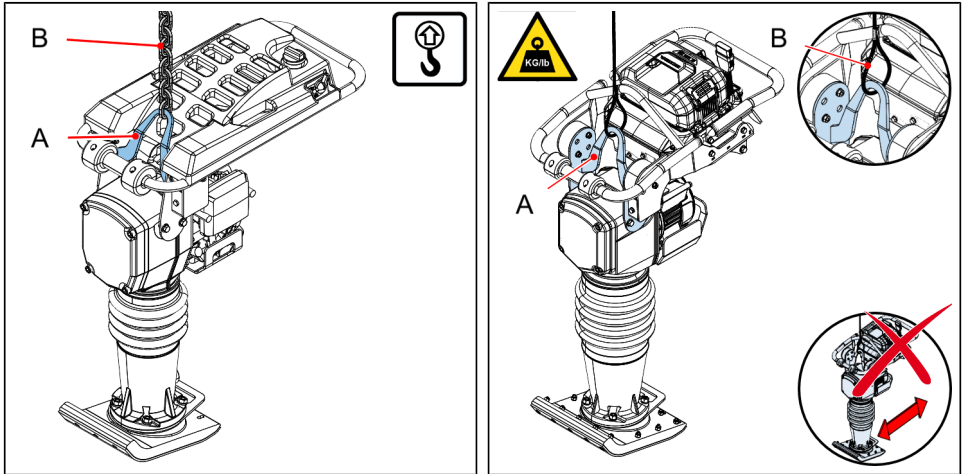

**WARNING**

Incorrect lifting can lead to serious injury. During lifting:

- Only attach the suitable lifting gear (B) to the lifting handle (A).
- Make sure that there are no people present below or in the immediate vicinity of the machine.
- Do not climb onto or lean into the machine during lifting.
- Make sure that the machine does not swing back and forth during lifting.

## 6.2 Moving the machine over a short distance



Illustration(s) can differ from the actual configuration.



**WARNING** The operator must always keep their feet clear of the machine.



**CAUTION** After disconnecting the fuel line (D) or opening the fuel tap (B), waste fuel can leak from the machine.

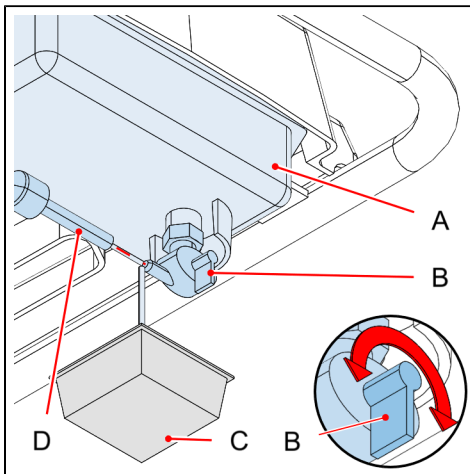

1. Drain the fuel tank (A) to prevent fuel from leaking from the fuel tank filler cap:
  - a. Put a container (C) below the fuel tank (A) to collect the waste fuel.
  - b. Close the fuel tap (B) at the bottom of the fuel tank (A).
  - c. Disconnect the fuel line (D).
  - d. Open the fuel tap (B) to drain the fuel tank (A).
2. Put the throttle lever into the [LOW/MIN]-position to prevent fuel leaks.

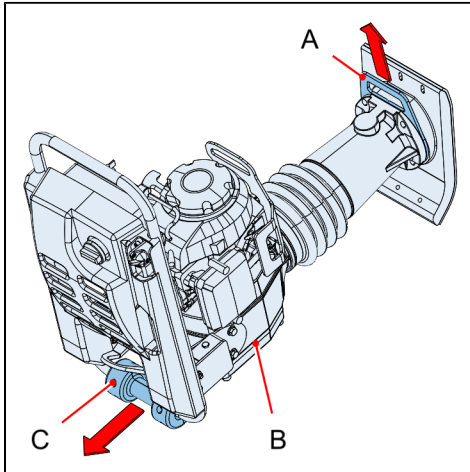

3. Carefully tilt the machine forwards to make it rest on the roller wheels (C).
4. Lift the transport handle (A) and roll the machine forwards or backwards.

## 7 Commissioning



### CAUTION

Before using the machine, the operator must always perform a few checks.

1. Make sure that the machine is not damaged.



If the machine is damaged upon delivery, contact the dealer immediately.

2. Make sure that all parts are present.



If the machine is missing parts upon delivery, contact the dealer immediately.

3. Make sure that there is fuel in the tank. Add fuel, if necessary. Refer to *Checking and adding fuel* on page 53.
4. Make sure that there is sufficient engine oil in the machine. Add engine oil, if necessary. Refer to *Checking and adding engine oil* on page 51.
5. Make sure that the engine is not leaking any engine oil or fuel.



### WARNING

If a leak is discovered, it is not allowed to use the machine until the leakage has been fixed.





## 8 Operation

### 8.1 Starting the engine

**WARNING**

Do not start the machine near spilled fuel. This can cause an explosion.

**CAUTION**

Before starting the engine:

- Make sure that the fuel tank is correctly filled.
- Make sure that the fuel tank filler cap is correctly installed.
- Make sure that the fuel tap at the bottom of the fuel tank has been opened.
- Make sure that there are no leaks or cracks in the fuel lines, fuel tank or fuel tank filler cap.
- When possible: place the machine on loose soil or gravel. It is best not to switch on the machine on hard surfaces (e.g. asphalt or concrete).
- Make sure that the engine oil level is correct.

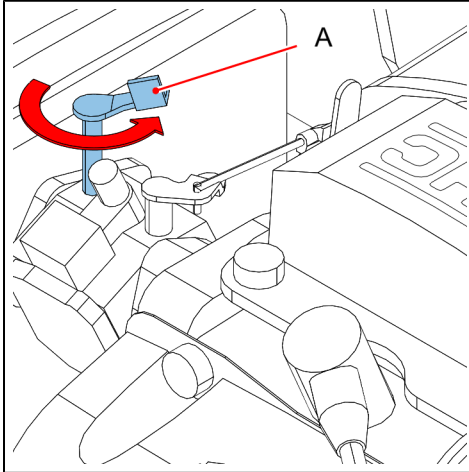

1. If applicable: adjust the choke (A):



**CAUTION**

- Cold engine: Completely close the choke.
- Warm engine: Do **NOT** use the choke.
- High air temperature: Do **NOT** use the choke.

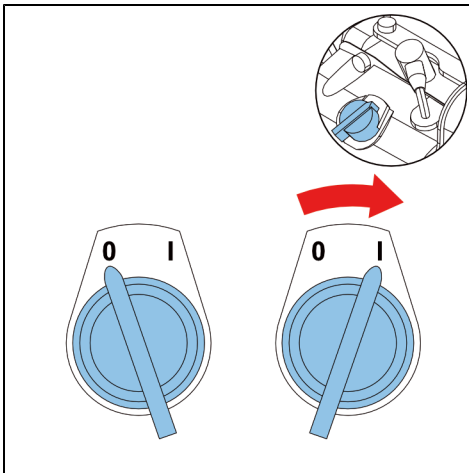
2. Completely push the throttle lever into the [LOW/MIN]-position.

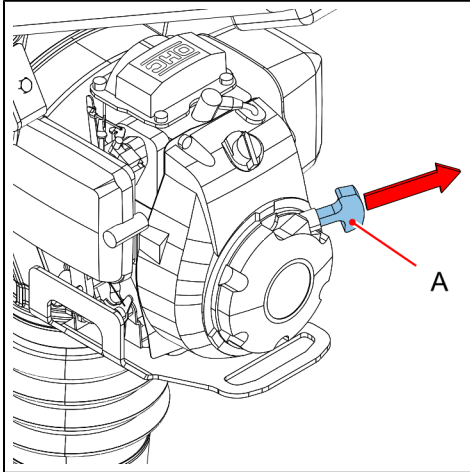

3. Turn the engine power switch to the [I]-position.



**CAUTION**

Slowly return the starter handle (A) as soon as the engine starts. Do not let the starter handle (A) hit the engine.

4. Pull the starter handle (A) to start the engine:
  - a. Pull the starter handle (A) until the mechanism engages.
  - b. Pull the starter handle (A) hard and fast to start the engine.



Some circumstances can require multiple pulls of the starter handle (A) before the engine is started:

- The machine is brand new and operated for the first time.
  - The machine was not used for a long period of time.
  - The machine had been completely drained of fuel.
  - Cold weather conditions.
5. If applicable: gradually open the choke until it is completely opened.

- When the engine is running, completely push the throttle lever into the [HIGH/MAX]-position.

**CAUTION**

Depending on the air and engine temperature, a cold engine should first warm up for max. 5 minutes before using the machine. During this warm-up, the throttle lever should be in the lowest position.

## 8.2 During operation

**WARNING**

Make sure not to damage any gas, water or electricity lines and/or tubes.



For an overview of the components of the machine, refer to *Description* on page 13.

- The operator must always be positioned behind the machine.
- Always use the guiding handle to operate the machine.
- Grab the guiding handle with both hands and walk slowly, guiding the machine in the desired direction.
- Make sure that the ramming shoe is always positioned parallel to the ground.
- Do not force or overload the machine during operation.

### 8.3 Switching off the engine



#### CAUTION

In the event of an emergency, switch the engine power switch to the [0]-position and close the fuel tap. Under all other circumstances follow the steps as described below, to prevent damage to the engine.

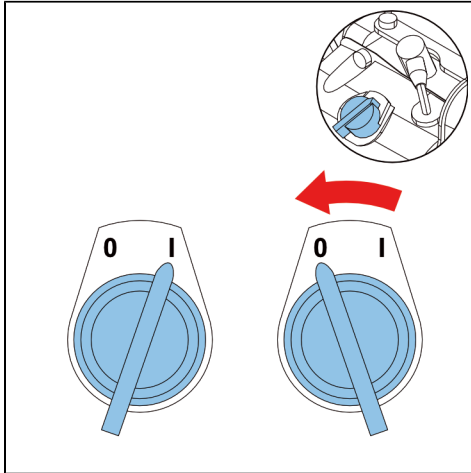

1. Completely push the throttle lever into the [LOW/MIN]-position.
2. Turn the engine power switch to the [0]-position.
3. Close the fuel tap.



## 9 Maintenance



### WARNING

- Read and observe all safety instructions before performing maintenance on the machine. Refer to *Safety* on page 19 for more information. Incorrect handling of the machine can result in injuries or damage to the machine.
- Only perform maintenance tasks when the machine is switched off and the machine is decommissioned. If this is not the case, this can result in serious injury or damage to the machine.
- Let the machine cool down before performing maintenance tasks. Use heat-resistant protective gloves if it is necessary to perform emergency work on the machine.



### CAUTION

- When cleaning the machine, make sure that water does not penetrate the machine. This can seriously damage the machine. This specifically applies to the air intake area and the electrical components.
- Do not use flammable liquids to clean the machine. Fumes from e.g. fuels or solvents can become explosive and cause serious injuries and damage to the machine.

## 9.1 Regular maintenance schedule



### WARNING

During maintenance, there is always a risk that the engine backfires or that the machine unexpectedly starts. This is especially applicable when the engine is hot and the engine power switch is in the [I]-position.

To prevent injury, always observe the following:

- Make sure that the engine has completely cooled down.
- Make sure that the engine power switch is in the [0]-position.
- Make sure that the cap has been removed from the spark plug.



### CAUTION

For a new machine, the operator must also perform the tasks that are mentioned in *Maintenance for a new machine* on page 50.

Interval	Maintenance task
Daily	Make sure that the controls function correctly.
	Make sure that all safety labels are still present and legible. Replace damaged or worn safety labels. Contact the dealer.
	Make sure that the machine is clean and free from debris.
	Check the fuel level. Fill up, if necessary. Refer to <i>Engine and fuel system maintenance</i> on page 51.
	Check the engine oil level. Fill up, if necessary. Refer to <i>Engine and fuel system maintenance</i> on page 51.
	Check for oil leakage.
	Check the bolts and nuts. Tighten, if necessary.
	Check the air filter. Clean, if necessary. Refer to <i>Frame maintenance</i> on page 56.



Interval	Maintenance task
	Check the oil level of the ramming system, using the sight glass. Fill up, if necessary.
	 Place the machine on a flat, even surface. The oil should be visible in the sight glass.
	Clean the cooling fins of the engine with compressed air.
	Perform a visual inspection for damage.
Every 5 hours	Check the air filter. Clean, if necessary. Refer to <i>Frame maintenance</i> on page 56.
Every 25 hours	Check the spark plug.
	Check the ramming shoe.
	Replace the air filter. Refer to <i>Frame maintenance</i> on page 56.
Every 100 hours	Replace the spark plug.
	Replace the engine oil. Refer to <i>Engine and fuel system maintenance</i> on page 51.
	Clean or replace the air filter. Refer to <i>Frame maintenance</i> on page 56.
	Check the rotational speed of the engine.
Every 300 hours/ Every year	Replace the fuel filter. Refer to <i>Engine and fuel system maintenance</i> on page 51.
	Replace the ramming system oil.
	Full maintenance inspection must be carried out by the dealer.

## 9.2 Maintenance for a new machine

Interval	Maintenance task
After the first 25 hours	Replace the engine oil. Refer to <i>Engine and fuel system maintenance</i> on page 51.
	Replace the ramming system oil.
	Check the rotational speed of the engine.
After the first 50 hours	Replace the ramming system oil.

## 9.3 Cleaning the machine

### **WARNING**

- Make sure that the machine is completely switched off before cleaning it.
- Make sure that water cannot reach the electrical parts of the machine.
- If the machine is equipped with a removable battery, remove it before cleaning the machine.

### **CAUTION**

- Depending on the type of compaction machine, it is only allowed to clean either the vibrating plate, rollers or ramming shoe with water.
- All other parts of the machine should be cleaned using an air-pressure cleaner and/or a dry cloth.
- Use a safety distance of 50 cm between nozzle and machine.

### **CAUTION**

- If water is used for cleaning the machine, make sure that the machine is completely dry before it is used.

## 9.4 Engine and fuel system maintenance

### 9.4.1 Checking and adding engine oil



Illustration(s) can differ from the actual configuration.



- Make sure that the machine has been switched off and the engine has completely cooled down.
- Running the engine without sufficient engine oil can cause serious damage to the engine.

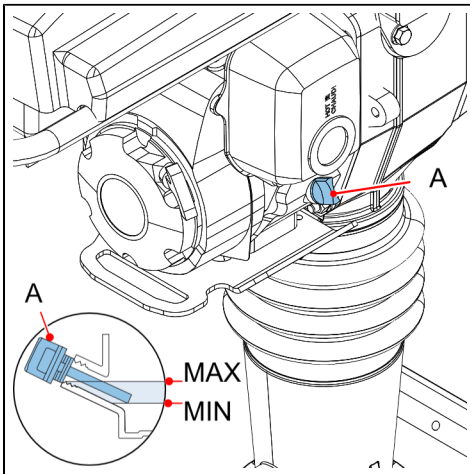

1. Place the machine upright on a level surface.
2. Allow the engine oil to drain back through the engine.



This can take several minutes.

3. Remove the engine oil filler cap (A).
4. Wipe the dipstick on the engine oil filler cap (A) clean.

5. Insert the dipstick into the filling hole to check the oil level in the crankcase.



**CAUTION**

Do not screw it in.



When the machine is on a level surface, the engine oil level must reach the edge of the filling hole.

6. If necessary, add engine oil until the engine oil level is correct.
7. Install the engine oil filler cap (A) again.

#### 9.4.2 Replacing the engine oil



Illustration(s) can differ from the actual configuration.



**CAUTION**

Drain the engine oil while the engine is still warm. This will make sure that the engine is completely and rapidly drained.

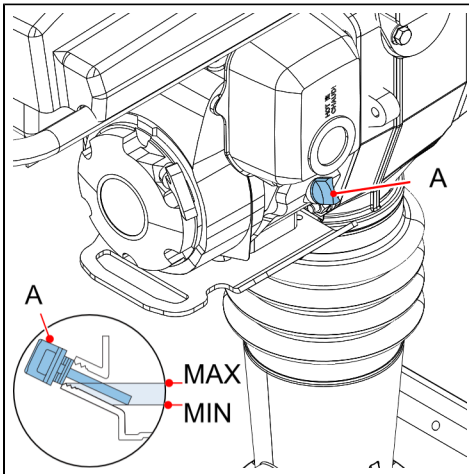

1. Place the machine on a level surface.
2. Put a container below the engine to collect any waste oil.

3. Remove the oil tank filler cap (A) and the drain plug on the engine.



**CAUTION**

Engine oil will come out of the engine. Allow the oil to drain completely.

4. Install the drain plug again.
5. Add engine oil to the correct level via the opening of the oil tank filler cap (A).



When the machine is on a level surface, the engine oil level must reach the edge of the filling hole.

6. Install the oil tank filler cap (A) again.
7. Dispose of the waste engine oil in accordance with (local) laws and regulations.

### 9.4.3 Checking and adding fuel



**WARNING**

- Switch off the machine and allow the engine to cool down before adding fuel to the machine.
- Do not start the engine near spilled fuel.
- Fuel is extremely flammable.



**CAUTION**

- Fill the fuel tank to the bottom edge of the filler neck.
- Do not spill fuel. Immediately wipe up any spilled fuel.



For the correct fuel type, refer to *Technical Data* on page 17.



Clean fuel filling funnel

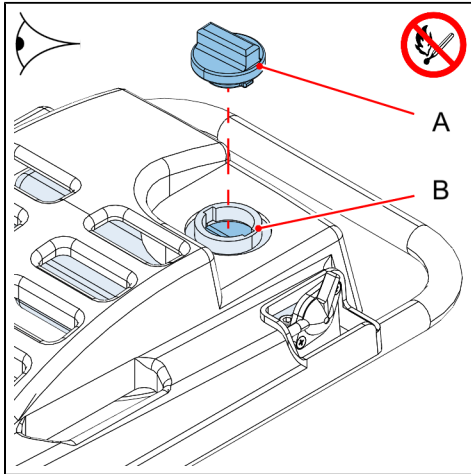

1. Place the machine in the upright position (operating position).
2. Open the fuel tank filler cap (A).
3. Perform a visual inspection of the fuel level.
4. If necessary, add fuel to the edge of the filler hole (B).
5. Install the fuel tank filler cap (A).

### 9.4.4 Replacing the in-line fuel filter



**CAUTION**

- Make sure that the engine has completely stopped.
- Make sure that the fuel tank has been completely drained.

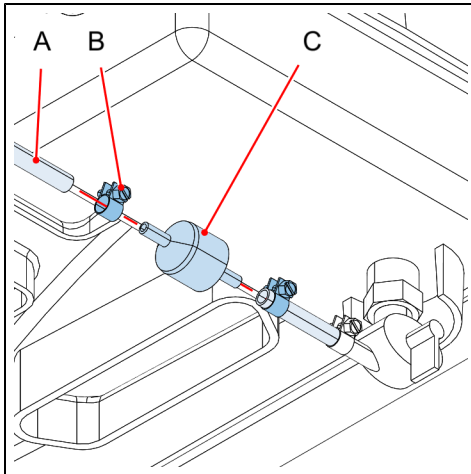

1. Completely close the fuel tap.
2. Put a container below the in-line fuel filter (C) to collect any waste fuel.
3. Loosen the hose clamps (B) of the fuel lines (A).
4. Disconnect the fuel lines (A) on both sides of the in-line fuel filter (C).
5. Remove the old in-line fuel filter (C).
6. Install the new in-line fuel filter (C) by performing the steps in reverse order.
7. Discard the old in-line fuel filter (C) and any waste fuel in accordance with (local) laws and regulations.
8. Inspect the fuel lines (A) and new in-line fuel filter (C) for fuel leaks before starting the machine again.

## 9.5 Frame maintenance

### 9.5.1 Cleaning or replacing the air filter unit



#### CAUTION

Never run the engine without an installed air filter unit. Failure to install an air filter unit onto the machine can result in contaminants entering the engine. This can cause serious damage to the engine.



- Cleanser and water
- Clean, soft, absorbent cloths
- Clean engine oil



Filter cartridge (If applicable)

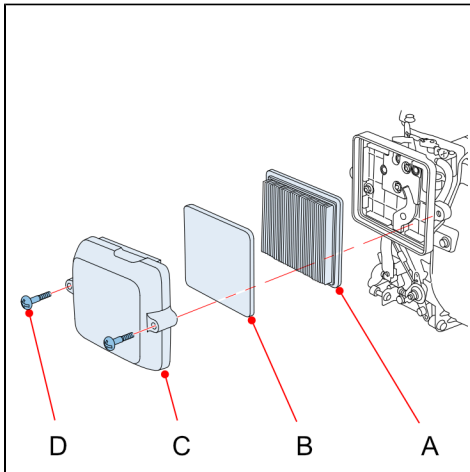

1. Switch off the engine and let it completely cool down.
2. Loosen the screws (D) of the cover (C).
3. Remove the cover (C) of the air filter unit.
4. Clean dust from the cover (C) with a clean, soft, absorbent cloth.
5. Use cleanser and water to clean the pre-cleaner element (B).
6. Saturate the pre-cleaner element (B) with clean engine oil.



7. Squeeze the pre-cleaner element (B) in a clean, soft, absorbent cloth until it is dry.

**CAUTION**

Do not twist the pre-cleaner element (B).

8. Clean the filter cartridge (A) by tapping it gently on a flat surface.

**CAUTION**

If the filter cartridge (A) is damaged, it must be replaced.

9. Install the air filter unit by following the steps in reverse order.



## 10 Troubleshooting

### 10.1 Troubleshooting procedure



If an error occurs that is not described in the table below, contact the dealer for more information.

Problem	Possible cause	Possible solution
Engine stalls or does not start.	Engine power switch is set to the [0]-position (OFF).	Set the engine power switch to the [1]-position (ON).
	Insufficient or no fuel.	Fill the fuel tank and check the fuel filter.
	Fuel tap is closed.	Open the fuel tap.
	Spark plug wire is loose.	Mount the spark plug cable.
	Spark plug is broken or dirty.	Contact the dealer.
	Fuel/air mixture is incorrect.	
	Ignition is damaged.	
	Adjustment is incorrect.	
Engine does not accelerate, is difficult to start or runs erratically.	Air filter is dirty.	Clean/replace the air filter.
	Oil level is too low.	Add engine oil.
	Loose connection between the carburettor and the engine.	Restore the connection.
	Spark plug is broken or dirty.	Contact the dealer.
	Gasket is leaking.	

<b>Problem</b>	<b>Possible cause</b>	<b>Possible solution</b>
Engine overheats.	Cooling fins are dirty or blocked.	Remove dirt or debris from the cooling fins.
	Oil level is too low.	Add engine oil.
	Air flow is restricted.	Clean/replace the air filter.
Engine runs, but ramming shoe does not tamp.	Clutch is damaged.	Contact the dealer.
	Connecting rod or crank gear is broken.	
	Pinion or clutch drum is broken.	
Engine runs smoothly, but the ramming is uneven.	Oil or grease on the clutch.	Dismantle the clutch and remove the oil or grease.
	Soil build-up on the ramming shoe.	Clean the ramming shoe. Refer to <i>Cleaning the machine</i> on page 50.
	Fuel filter is clogged.	Replace the fuel filter.
	Incorrect rotational speed of engine.	Adjust the rotational speed of the engine.
	Clutch is damaged.	Contact the dealer.
	Springs are broken or worn.	

## **11 Environment**

The life cycle of the S54B depends on maintenance, operating hours and use, and environmental conditions, such as dust, pollution, humidity or temperature. Good maintenance will keep the S54B in a good and reliable condition for a long time.

### **11.1 Decommissioning and waste disposal**

At the end of its life cycle, let a qualified company with the required permits dismantle the machine. This will make sure that the dismantling and waste disposal is done in accordance with applicable (local) laws and regulations.



## 12 Terms of warranty

The warranty is subject to the following limitations. The warranty period for products supplied by TOBROCO Machines BV starts on the date shown on the purchase document.

The warranty conditions can depend on the agreement made with the TOBROCO Machines BV dealer.

For more information, ask the TOBROCO Machines BV dealer about the applicable warranty duration and conditions.





## 13 Appendix

### 13.1 Dealer details

The dealer of this S54B is:

--

### 13.2 Machine-specific information

Serial number:
Operating hours:
Customer:
Specific information:

### 13.3 Maintenance Log

**Model:** ..... **Serial number:** .....

Date	Maintenance provided by	Hours	Service procedure

<b>Date</b>	<b>Maintenance provided by</b>	<b>Hours</b>	<b>Service procedure</b>

---

Date	Maintenance provided by	Hours	Service procedure



# TOBROCO

GROUP

---

**TOBROCO Machines BV**

Industrielaan 2  
5061 KC Oisterwijk  
Netherlands

[www.tobroco.com](http://www.tobroco.com)